

Q-Gun™ Series

200, 300, 400 Amp MIG Guns

Issued Jan. 2013 • Index No. SPEC Q234-1.4

400 amp Q-Gun™ MIG Gun shown with curved handle, medium 45° rotating neck and standard trigger.



Industrial Workhorse 200, 300 and 400 amp Q-Gun™ MIG Guns are easy-to-use and designed for exceptional performance and comfort in the most demanding industrial environments.

Stay-Tite™ Technology

Long-lasting power cable compression fittings and necks with large tapered gun connections combine to form the foundation of Bernard Stay-Tite™ Technology. This technology ensures optimal conductivity to increase weld consistency and lessen heat output while improving product durability.

All Guns are Not Created Equal.

A MIG gun should be durable, easy-to-use and customized to your specific application. Our MIG guns put you in control: you choose the options you need and we'll build a gun to last.

Centerfire™ Contact Tips, Nozzles and Diffusers are easy-to-use and high performing - they provide better arc starts, less spatter and more consistent welds - and also last up to three times longer than competitive brands.

Necks available in fixed, rotatable and multiple length options for optimal weld accessibility and improved operator comfort. Rotatable necks changeover without tools.

Jump Liner allows quick neck change and replacement of only most commonly worn or clogged liner area, which reduces the amount of time a gun is offline and minimizes inventory.

Multiple handle and trigger options to increase operator comfort.

Power cable equipped with Stay-Tite™ Technology and internal gas hose that resists kinking, improves gas flow and feedability.

Back end with durable rigid strain relief and easily interchangeable direct plugs and trigger leads connect to wire feeders and machines from major manufacturers and allow simple maintenance.

Q-Gun	Amperage Ratings				Description
	Duty Cycle				
	100% NEMA	100% CE	60% CE	35% CE	
Q200	250	200	240	325	CO ₂ Gas
	n/a	175	200	240	80%AR20%CO ₂
Q300	350	320	370	470	CO ₂ Gas
	n/a	270	310	390	80%AR20%CO ₂
Q400	400	350	425	520	CO ₂ Gas
	n/a	285	350	440	80%AR20%CO ₂

Made with
Pride and without
Compromise in the **USA**

Bernard

An Illinois Tool Works Company
449 West Corning Road, Box 667
Beecher, Illinois 60401 USA

Phone: 800-946-2281 (US Only) 708-946-2281 (Outside US)
Fax: 708-946-6726
For more information, visit us at BernardWelds.com



Replacement Parts List

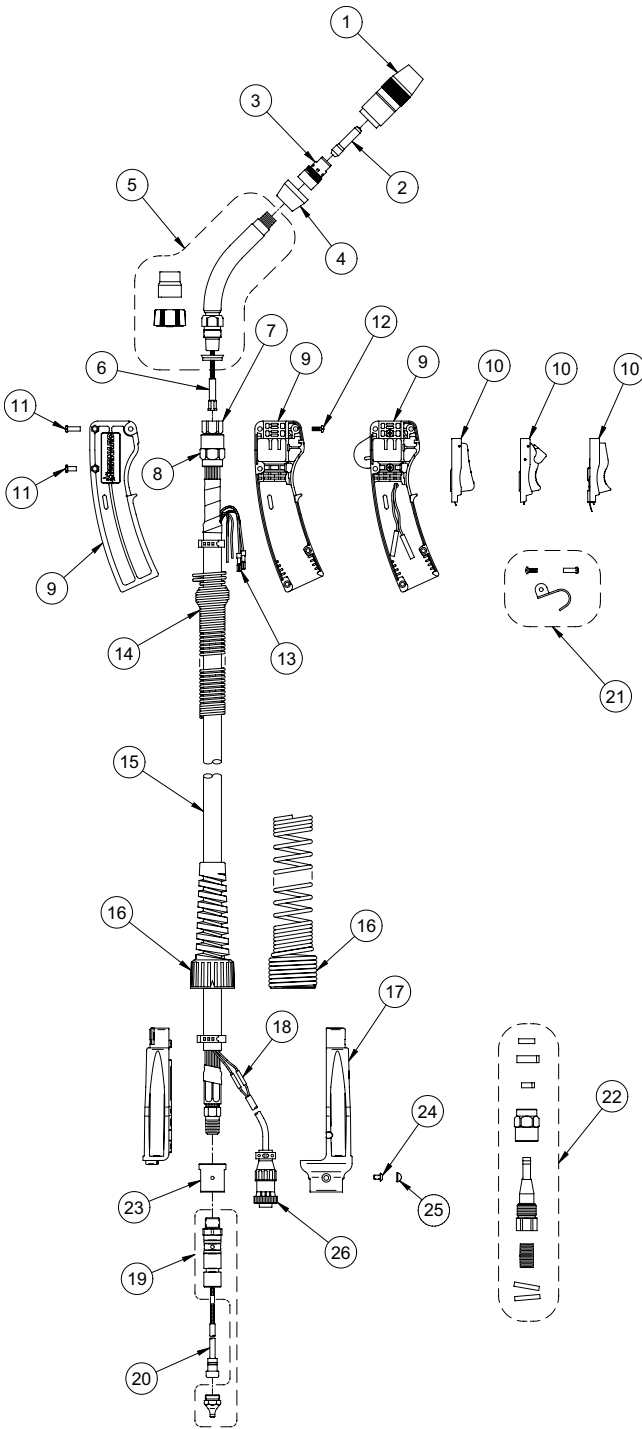

ITEM #	Q200 PART #	Q300 PART #	Q400 PART #	DESCRIPTION
1	See Centerfire Spec Sheet			Nozzle Assy
2	See Centerfire Spec Sheet			Contact Tip
3	See Centerfire Spec Sheet			Gas Diffuser
4	See Centerfire Spec Sheet			Cap
5	See Neck Spec Sheet			Neck
6	See Jump Liner Spec Sheet			Jump Liner
7	4213B		4313B	Stay-Tite™ End Fitting
8	4305		1540003	Stay-Tite™ Cone Nut
NS	4991		1520017	Conduit Clamp (2 Req'd)
NS	4823		4939	Jacket Clamp (2 Req'd)
9	1880155		1880198	Handle Kit, Standard Locking*
				Handle Kit, Locking Trigger*
				Handle Kit, Dual Pull Trigger*
	N/A		DSA-1	Handle Kit, D/S, Std. Trigger*
				Handle Kit, D/S, Locking Trigger*
10			5662	Trigger, Standard
			5662L	Trigger, Locking
			2690001	Trigger, Dual Pull, 3 Wire (With Insulated Terminals)
11			4207	Post Fastener (1 Req'd - Q200 & Q300) (5 Req'd - Q400)
	2030004		N/A	Post Fastener, Short (4 Req'd)
12			4209	Handle Screw (5 Req'd)
13			2660001	Terminal, Quick Disconnect (2 Req'd)
14	N/A		2520042	Handle Spring
15	1060120	1060108	1060114	8' (2.44 m)
	1060121	1060109	1060115	10' (3.05 m)
	1060122	1060110	1060116	12' (3.66 m)
	1060123	1060111	1060117	15' (4.57 m)
	1060124	1060112	1060118	20' (6.10 m)
	1060125	1060113	1060119	25' (7.62 m)
16	2520033		2520041	Strain Relief
17				Rigid Strain Relief Kit (Includes: Top & Bottom Halves)
	2520073			Strain Relief with Installed Gas Pin (Bernard Direct Plug)
	2520069			Strain Relief (Euro® Direct Plug)
	2520066			Strain Relief (All Other Direct Plugs)
18			4932	Butt Connector (2 Req'd)
19	See Direct Plug Spec Sheet			Direct Plug Components
20	See Liner Spec Sheet			Liner
21			1790002	Hang up Hook Kit (Includes: Hook, Screw, & Post)
22	1982	1983Q	1984Q	Rear Stay-Tite™ Repair Kit†
23			1010027	Adaptor Block (Not Req'd on Bernard or Euro® Direct Plug)
24			2280056	Screw, Strain Relief (Not Req'd on Bernard Direct Plug)
25			1620003	Screw Cover, Strain Relief
26			GN2021	Electrical Plug-Non D/S (Not Req'd on Bernard or Euro® Direct Plug)
			20006A	Electrical Plug-D/S (Not Req'd on Bernard or Euro® Direct Plug)

*1880155 & 1880198 Handle Kits include halves, screws & posts.

*DSA-1 Handle Kits include halves, screws, posts, toggle switch and guard.

†1982, 1983Q & 1984Q Rear Cone Nut Repair Kits include jacket clamp, conduit clamp, cone nut, end fitting, nipple, spacer & butt connectors.

Bernard™ is a trademark of Illinois Tool Works Inc. Other brands mentioned are for reference only and are the registered trademarks of their respective companies, and are not affiliated with Illinois Tool Works Inc.