

TECHNICAL GUIDE

TOUGH GUN REAMER TT Series

- SAFETY & WARRANTY INFORMATION
- INSTALLATION
- MAINTENANCE GUIDE
- TECHNICAL DATA
- OPTIONS
- EXPLODED VIEW & PARTS LIST
- TROUBLESHOOTING
- ORDERING INFORMATION

Certified QS 9000 TE.
Please read instructions prior to use.
Save this manual for future reference.

TABLE OF CONTENTS

WARRANTY

1.0 - INSTALLATION

1.1 INSTALLING TOUGH GUN REAMER	4
1.2 AIR MOTOR LUBRICATION	4
1.3 WIRING INTERFACE CONNECTIONS	4
1.4 ACCESS TO ELECTRICAL AND PNEUMATIC CONTROLS	5
1.5 CIRCUIT BOARD LOGIC INVERSE	5
1.6 LED INDICATORS	5

2.0 - OPERATION

2.1 NOZZLE INSERTION HEIGHTS	6
2.2 PROGRAMMING EVENTS SEQUENCE	6
2.3 V-BLOCK SETUP	6
2.4 MANUAL REAMER SETUP	7
2.5 FLOW CONTROL VALVES	7

3.0 - MAINTENANCE

3.1 AIR MOTOR REPLACEMENT	7
3.2 REPLACEMENT OF PRINTED CIRCUIT BOARD	8
3.3 CUTTER REPLACEMENT	8
3.4 BELT REPLACEMENT	8
3.5 SOLENOID VALVE REPLACEMENT	9
3.6 SCHEDULED PROGRAM	9

4.0 - TECHNICAL DATA

4.1 PNEUMATIC DIAGRAM	9
4.2 ELECTRICAL SCHEMATIC	10
4.3 CUTTER AND V-BLOCK CHART	10

5.0 - EXPLODED VIEW & PARTS LIST 12

6.0 - TROUBLESHOOTING 13

7.0 - SPRAYER

7.1 OPTION (S): ANTI-SPATTER SPRAYER	13
7.2 OPERATION: PROGRAMMING EVENTS SEQUENCE	14
7.3 SPRAYER MAINTENANCE	14
7.4 SPRAYER TROUBLESHOOTING	14
7.5 SPRAYER PARTS LIST	15

8.0 - OPTIONS

8.1 REAMER STAND	15
8.2 MULTI-FEED READY	16
8.3 SPRAYER FLOW CONTROL	17
8.4 WIRE CUTTER	17

9.0 - TOUGH GUN ORDERING INFORMATION

BACK COVER

WARRANTY

Tregaskiss equipment and parts are warranted to be free of defects in material and/or workmanship as stated below. If within that period, any Tregaskiss gun or part thereof is found to be defective under normal and recommended use, Tregaskiss will at their option, repair, replace or issue credit for the value of the defective unit. All claims against this warranty must be submitted through a factory-authorized distributor. Use of non-Tregaskiss parts and/or consumables with these guns may damage or severely limit performance of the TOUGH GUN and may limit or void any warranties. Tregaskiss will not assume responsibility for incidental damages or expenses by any defect whatsoever.

TOUGH GUN MIG guns and components -	120 days
TOUGH GUN handles and trigger switches -	Lifetime
TOUGH GUN Reamer and components -	1 year
TOUGH GUN Robotic peripherals: Clutch, Sprayer, Wire Cutter, Clutch Disc and Robotic Arms -	1 year

Customer Returns

- Returned boxes must have a RA # and return address on boxes when received.
- Torches returned under warranty must be complete including consumables.
- Returned Trials must have bottom portion of Trial form completed and sent here before RA # is issued.
- Products returned that were previously installed on torches cannot be put back into inventory (i.e. water-cooled goosenecks).
- No credit on returned specials
- Any products left here for more than 30 days after contact with the customer will be shipped back at their expense.
- If product is being returned for Warranty Repair or Replacement, a Return Authorization Number must be obtained from the factory. No charge replacements or repaired products will be sent out once returned product has been evaluated and warranty has been determined. If a replacement needs to be sent immediately, a purchase order number is required and the goods will be billed until warranty is determined.

THANK YOU...

for selecting a TOUGH GUN REAMER. Manufacturing operations demand extremely dependable robotic equipment. With this in mind, the TOUGH GUN REAMER was designed and engineered to be a reliable tool to support high production within a robotic cell. As the name implies, the TOUGH GUN REAMER is made from durable materials and components engineered to perform in a rugged, robotic welding environment.

The instructions and illustrations in this technical guide make it easy for you to maintain your TOUGH GUN REAMER. **Please read, understand, and follow all safety procedures.** Keep this Technical Guide booklet as a handy reference when ordering complete guns, parts and special options.

For technical support and special applications, please call the Tregaskiss Technical Service Department at (800) 787-6966 or fax (800) 665-0400. Our trained technicians are available between 8:30 AM and 4:30 PM, and will answer your application or repair questions.

Tregaskiss also manufactures complete robotic MIG gun systems designed and engineered to perform as a team in the high-volume robotic production environment. Components include TOUGH GUN ROBOTIC air-cooled and water-cooled MIG guns, TOUGH GUN CLUTCH and gun-mount arms. Contact your Tregaskiss representative or Tregaskiss Ltd. for further information.

GENERAL SAFETY

Before installation or operation of the TOUGH GUN REAMER, please read and understand all safety precautions listed below. Failure to follow these instructions may result in personal injury or damage to the equipment.

1. Do not remove or deface warning and instruction labels from the unit.
2. Ensure that all equipment in the area is disabled and locked out before setting up, adjusting or conducting any work.
3. Ensure that electrical and pneumatic power to unit is off before setting up, adjusting, or conducting any work.
4. Check that electrical and pneumatic connections comply with the codes applicable to your country and state.
5. Keep hands away from unit while in operation.
6. For additional safety information, please refer to the following publications:

ANSI STANDARD Z49.1, SAFETY IN WELDING AND CUTTING,
American Welding Society, 550 LeJeune Rd. P.O> Box 351040, Miami, FL 33126

ANSI STANDARD, SAFETY OR ROBOTS AND ROBOT SYSTEMS,
American National Standards Institute, 1430 Broadway, New York, NY 10018

NFPA STANDARD 70-1978. NATIONAL ELECTRIC CODE,
National Fire Protection Association, 1470 Atlantic Avenue, Boston MA 02210

1.0 - INSTALLATION

1.1 INSTALLING TOUGH GUN REAMER

Ensure power supply is off and disconnected before proceeding.

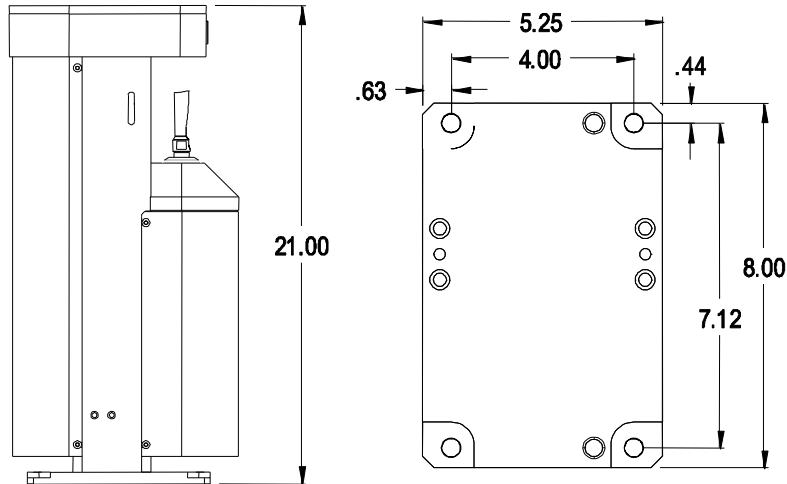

TT Series

Mounting Hole Locations
and Footprint

MOUNTING REAMER

- The REAMER should be installed within the weld cell at a convenient location. Be sure to consider movable fixtures and the confines of the robot.
- Affix REAMER base to sturdy platform using four (4) 3/8" dia. bolts in the holes provided.
- If using optional adaptor plate, first mount plate to stand using two (2) supplied 1/2" bolts. Then mount reamer to this plate.

CONNECTING AIR SUPPLY – WARNING – PUSH RESET BUTTON BEFORE CONNECTING AIR LINE.

- Use only filtered, lubricated air.
- REQUIREMENTS - **IMPORTANT:** 80 to 100 PSI at 16 CFM (5.0-7.0 BAR at 450 LPM) at the Reamer.
- Use an air supply line with an inside diameter of 3/8" and connect to 1/4" female NPT inlet located on the side of the valve base.

1.2 AIR MOTOR LUBRICATION

An air line lubricator (not supplied) must be mounted in the air line of the Reamer. The Lubricator should be set to feed one drop of oil for every 50-75 CFM of air going through the motor. The lubricant can be air motor oil or light grade hydraulic oil with a viscosity rating of 150 VC 15-20 (SAE 5W).

1.3 WIRING INTERFACE CONNECTIONS

WARNING: The following connections should only be performed by qualified technicians. Damage to equipment will occur if connections are incorrect.

To interface the REAMER with the controller, 4 electrical connections are required.

- ORANGE LEAD - CYCLE START INPUT (.25 AMP)
- WHITE LEAD - 0 VDC SUPPLY .5 AMP
- RED LEAD - 24 VDC SUPPLY .5 AMP
- GREEN LEAD - JAWS UNCLAMPED OUTPUT (LOAD CAPACITY = .25 AMP)
- BLACK LEAD – OPTION (INPUT)

NOTE: The pre-wired interface receptacle uses the above colour codes.

OPERATION NOTES:

- Connection 2 - Red Lead. Operates the internal logic with 24 VDC supply
- Connection 3 - Green Lead. Cycle complete output signal either +24 VDC for sourcing or 0-sinking logic (ref. Logic Inverse pg. 5)
- Connection 4 - Orange Lead. Cycle start input signal (pulse signal max. .5 seconds) either +24 VDC or 0 VDC for sinking logic (ref. Logic Inverse pg.5).

NOTE The TOUGH GUN REAMER is capable of both sourcing or sinking (high or low) inputs and outputs:

1.4 ACCESS TO ELECTRICAL AND PNEUMATIC CONTROLS

WARNING!

Ensure power supply is off and disconnected before proceeding.

- To access the electronic circuit board for installation or service of the REAMER, simply loosen the 4 Allen head screws and remove rear motor shroud for access to switches.
- To reinstall the covers, place motor shroud into position and tighten the 4 Allen screws.

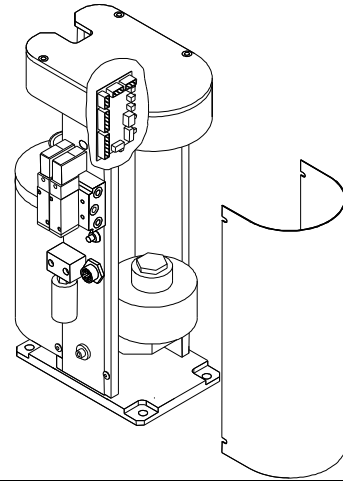

1.5 CIRCUIT BOARD LOGIC INVERSE

- **CAUTION! Before start-up ensure all connections are correct or damage to the TOUGH GUN REAMER may occur.**
- **NOTE:** The TOUGH GUN® REAMER is factory set for sourcing inputs and outputs.
- The control logic requirement for some installations may require an inverse of the logic provided. The inverse logic is 0 VDC low (sinking) input or outputs.
- To switch from sourcing to sinking, the switches located inside the motor shroud must be accessed. Refer to "Access to Pneumatic and Electrical Controls (see above) for directions.
- Although the circuit board is protected, Tregaskiss suggests disconnecting the power before moving the switches.
- The switches are located on the bottom right hand corner of the circuit board.
- The output signal (unclamped signal) can be altered to either sourcing (high) or sinking (low) by moving the switch (SW3) to the position indicated on the diagram. (page 10)
- The input signal (start signal) can be altered to either sourcing (high) or sinking (low) by moving the switch (SW2) to position indicated on the diagram. (page 10)
- The Option signal (sprayer) can be altered to either sourcing (high) or sinking (low) by moving the switch (SW1) to position indicated on the diagram. (page 10)
- **REFER TO ELECTRICAL SCHEMATIC pg 10**

1.6 L.E.D. INDICATORS

The L.E.D. indicators mounted on the front of the reamer supply visual information regarding cycle status. This information may be used for both installation and maintenance to verify proper operation. When REAMER is idle, L.E.D. status should be:

"Reamer Home" - ON

"Reamer Ahead" - Off

"Unclamped" - ON

"**Reamer Home**" - indicates that the lift cylinder has retracted, the cutter is at the bottom of its stroke and the limit pin is activating the lower limit switch.

"**Reamer Ahead**" - indicates that the Reamer has reached full upper stroke and the limit pin is activating the upper limit switch.

NOTE: Full stroke extension of the lift cylinder is 3/8" (9 mm) shorter in the automatic mode. Use the insertion depth chart in section 2.1 for proper depth. If manual set-up is used (Section 2.4) for insertion depth, cutter may not travel deep enough.

"**Unclamped**" - indicates that the clamp cylinder is fully retracted, releasing the clamp mechanism and supplying an output signal that the cycle is complete (via the limit switch mounted next to the clamp cylinder)

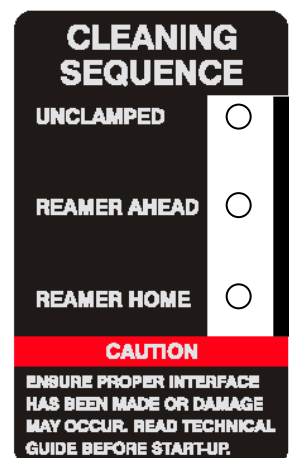

2.0 OPERATION

2.1 NOZZLE INSERTION HEIGHTS

TT Series Reamers

Cutter	Size	RETAINING HEAD		
		404-3	404-20/404-30	454-1
RC-06	3/8"	0.023 below	.025 below	.266
RC-12	3/4"	.110 below	.110 below	.466
RCT-01	5/8"	0.030	0.060	.716
RCT-04	1/2"	.219 below	.065	.065

- **DO NOT** use manual overrides for setup. Use automatic cycle. Cutter stroke will vary between manual and automatic cycles. Measurements are based on new cutter styles and a 14mm wire stickout.

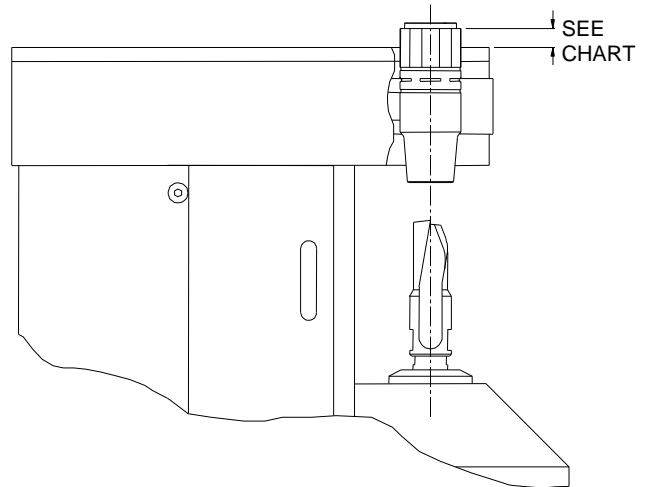

2.2 PROGRAMMING EVENTS SEQUENCE

1. Verify Reamer input showing "Clamps Open".
2. Position the robot to place the MIG gun at a right angle to the unit and to insert the gun to the proper depth, centered and pressed against the V-block (see Section 2.1 "Nozzle Insertion Parameters").
3. Cycle Start - Supply output signal from the robot controller. Pulse output for .5 seconds.
4. Wait and verify input from Reamer for cycle (clamps closed).
5. Reamer performs cleaning cycle.
6. Wait and verify input from Reamer for cycle complete (Clamps Open).
7. The robot can now be safely removed from the Reamer clamps to the next position.

If using anti-spatter sprayer:

1. After reaming, center the nozzle one (1) inch (25 mm) above the spray head.
2. Supply output signal from robot controller to the sprayer for about .5 seconds (increase or decrease spray time as required).
3. Move robot to next position.

2.3 V-BLOCK SETUP

WARNING! ENSURE POWER SUPPLY IS OFF AND AIR IS DISCONNECTED BEFORE PROCEEDING.

- Remove four cover screws.
- Lift clamp cover off.
- Lift and rotate V-Block so desired size faces jaws.
- **NOTE:** Numbers are stamped into the V-Blocks. The number refers to the outside diameter of the nozzle i.e.: 0938 =.938O.D..

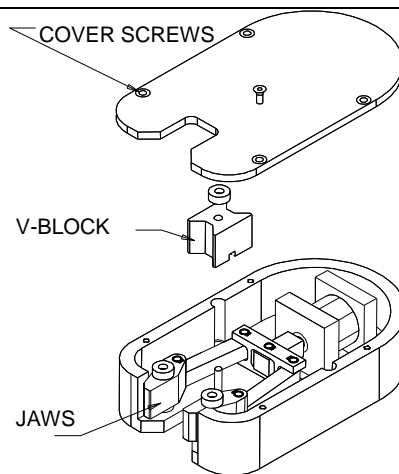

V-BLOCK PART #	NOZZLE OUTSIDE DIAMETER
TR-2150	0.850", 0.938"
(4 sides)	1.062" AND 1.106"
TR-2151	.938" AND .978"
TR-2152	1.062" AND 1.125"
TR-2153	.813" AND 1.00"
TR-2154	.078"
TR-2155	.830"
TR-2156	.875"
TR-2157	.591" (15mm)
TR-2158	.984" (25mm)

2.4 MANUAL REAMER SETUP

NOTE:

- The manual override valve screws allow confirmation that the lift cylinder and jaw clamping air circuit is operational. It should not be used for gauging the cutter depth (see section 2.1 for insertion depths).
- To manually start the TOUGH GUN® REAMER, locate the screws on the spindle air valve and clamp and motor air valve. Rotate these screws clockwise and the REAMER will function.
- **NOTE:** The reset button should be pressed prior to manual setup to reset all circuitry.

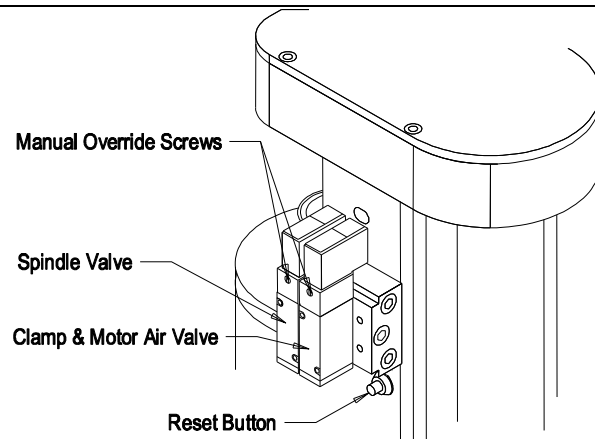

2.5 FLOW CONTROL VALVE(S)

OPERATING NOTES: The flow control valve(s) provide a smooth, constant feed of the cutting tool. The feed rate is dependant on the amount of spatter accumulated. If a smaller amount of spatter accumulates, the feed can be set faster. A feed rate that is set too fast may stall the motor.

ADJUSTING THE FLOW CONTROL VALVE(S)

- **NOTE:** Reamers prior to serial #TT-5338 utilized two flow controls for advancing and retracting the feed unit.
- There is a flow control valve for adjustment of the up speed of the feed head. The down (retract) speed is fixed. The feed rate may require adjusting for different applications.
- The valve controls the rate at which air is released on the exhaust side of the cylinder
- To increase feed rate on the nozzle, the valve would have to be opened, which allows air to flow out of the cylinder, thereby increasing speed.
- To decrease feed rate into the nozzle, the valve would have to be closed, which slows air flow out of the cylinder causing feed to slow down.

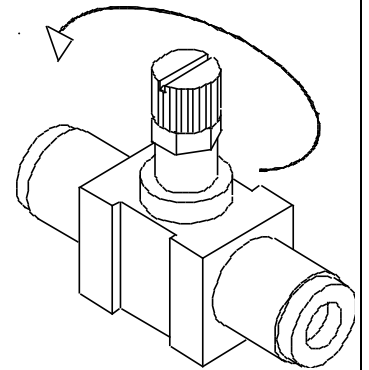

3.0 MAINTENANCE

3.1 AIR MOTOR REPLACEMENT

- Loosen 4 screws and remove motor shroud
- Remove tension lock screw.
- Push motor in to release belt tension.
- Remove belt
- Release air lines from quick disconnect air fittings.
- Reverse order for reassembly.

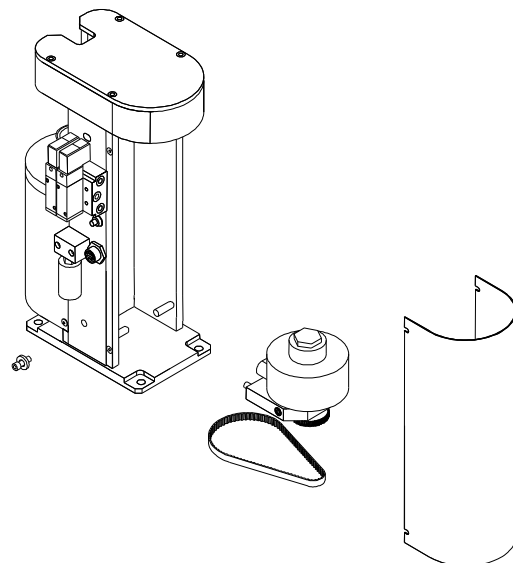

3.2 REPLACEMENT OF PRINTED CIRCUIT BOARD

- Loosen 4 screws and remove motor shroud
- Remove connectors from board being careful not to damage wiring
- Remove the fasteners which secure board to reamer body.
- Board can now be carefully removed from the unit and a new one installed.
- Once located in the proper position, secure board by tightening fasteners.

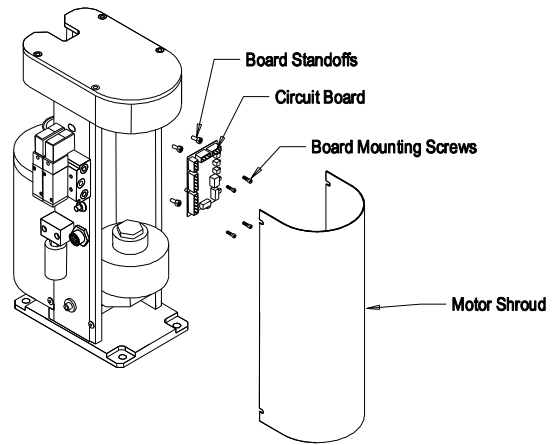

3.3 CUTTER REPLACEMENT

- Remove cutter using 5/8" wrench and the supplied 9/16" wrench.
- The cutter is removed by turning counterclockwise when viewed from above.
- Considerable force may be required to loosen the cutter since it tightens naturally as the reamer operates

INSTALLING CUTTER

The cutter is installed by threading it clockwise into the top of the extension shaft.

NOTE: The application of anti-seize compound to the threads of the REAMER cutter will assist in easy removal in the future.

9/16 Wrench (supplied) →

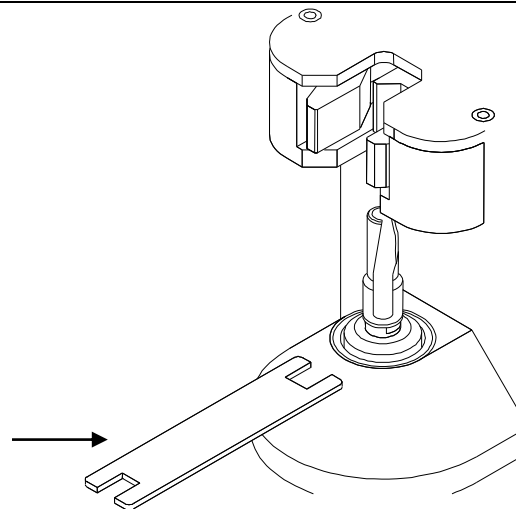

3.4 BELT REPLACEMENT

- Loosen 4 screws and remove motor shroud.
- Remove tension lock screw.
- Push motor in, to release belt tension.
- Remove belt.
- Reverse order for reassembly.

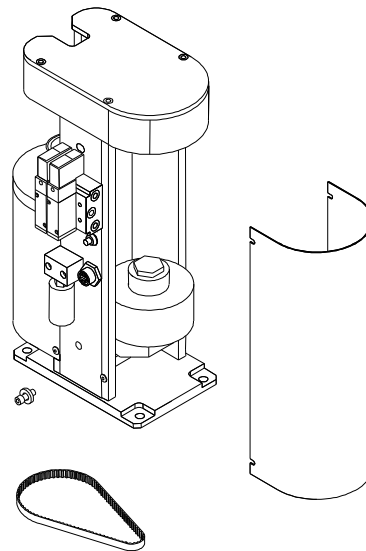

3.5 SOLENOID VALVE REPLACEMENT

- Shut off power to Reamer.
- Shut off air supply to Reamer.
- Remove motor shroud.
- On Reamer circuit board, remove valve coil wires.
- Loosen and remove (2) solenoid valve screws.
- Remove solenoid valve and gasket.
- NOTE: New gasket must be installed when replacing valve.
- Reinstall new gasket and valve and tighten screws to 12 in./lbs.
- Reconnect valve coil wires to Reamer circuit board.
- Reinstall the motor shroud.

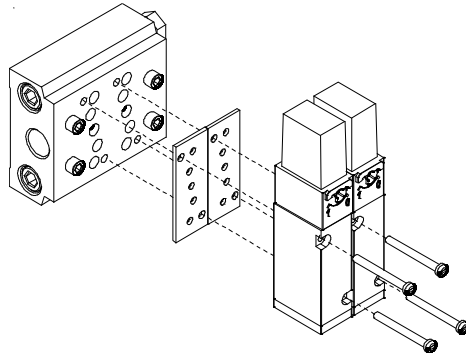

3.6 SCHEDULED MAINTENANCE PROGRAM

The TOUGH GUN® REAMER will require a periodic maintenance program to ensure a reliable service life. The following schedule is recommended.

DAILY

- Ensure spindle cover area is clear of spatter.
- Visually check oil level in lubricator reservoir
- The life of the air motor is dependent on a consistent supply of oil.
- Visually check air lines and interface cables for leaks and fraying.
- Clean clamp jaw surfaces to ensure proper nozzle gripping.

WEEKLY

- Visually check the REAMER cutter. The service life of the cutter is dependant on the type of application.
- In lighter duties, the cutter may last indefinitely. However, it should be inspected for dullness, clogging and possible breakage.
- Ensure belt tension lock screw is securely tightened.

YEARLY

- Replace drive belt (reference "Belt Replacement" pg. 8).

4.0 TECHNICAL DATA

4.1 PNEUMATIC DIAGRAM

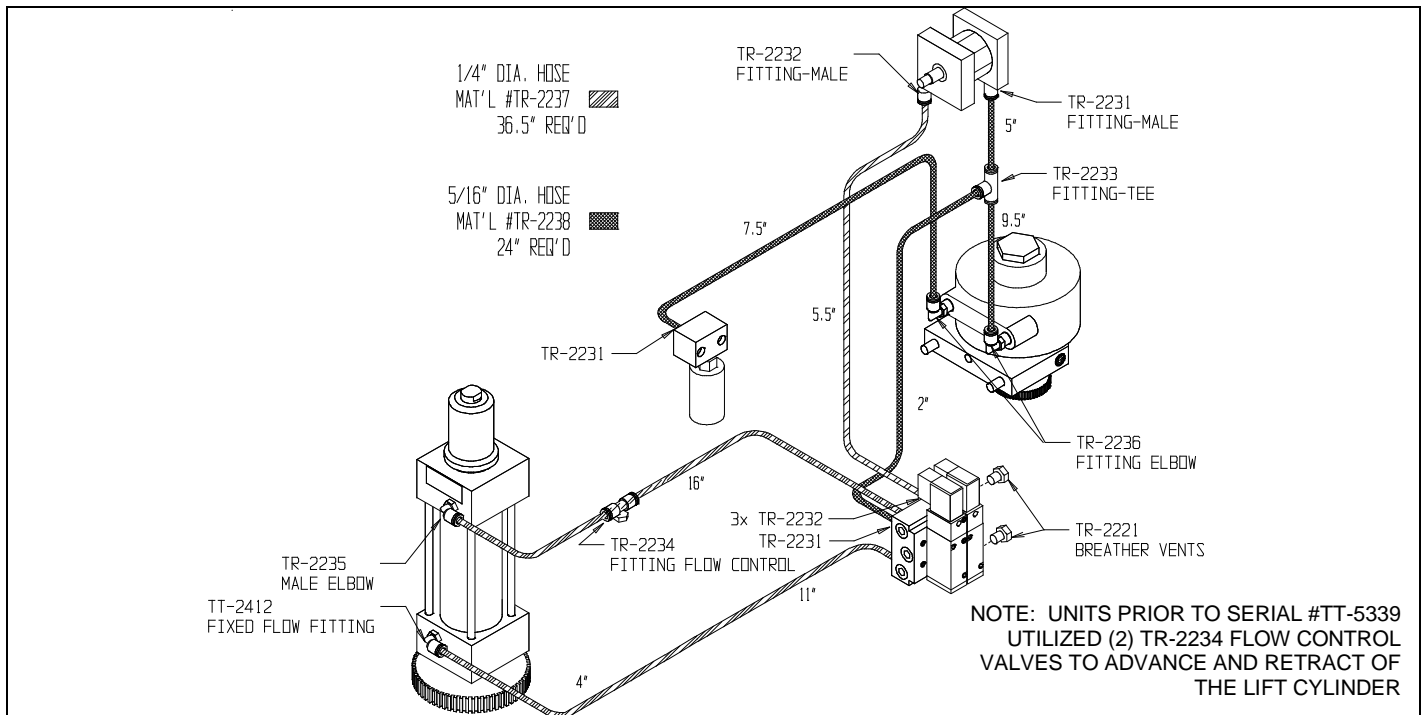

4.2 ELECTRICAL SCHEMATIC

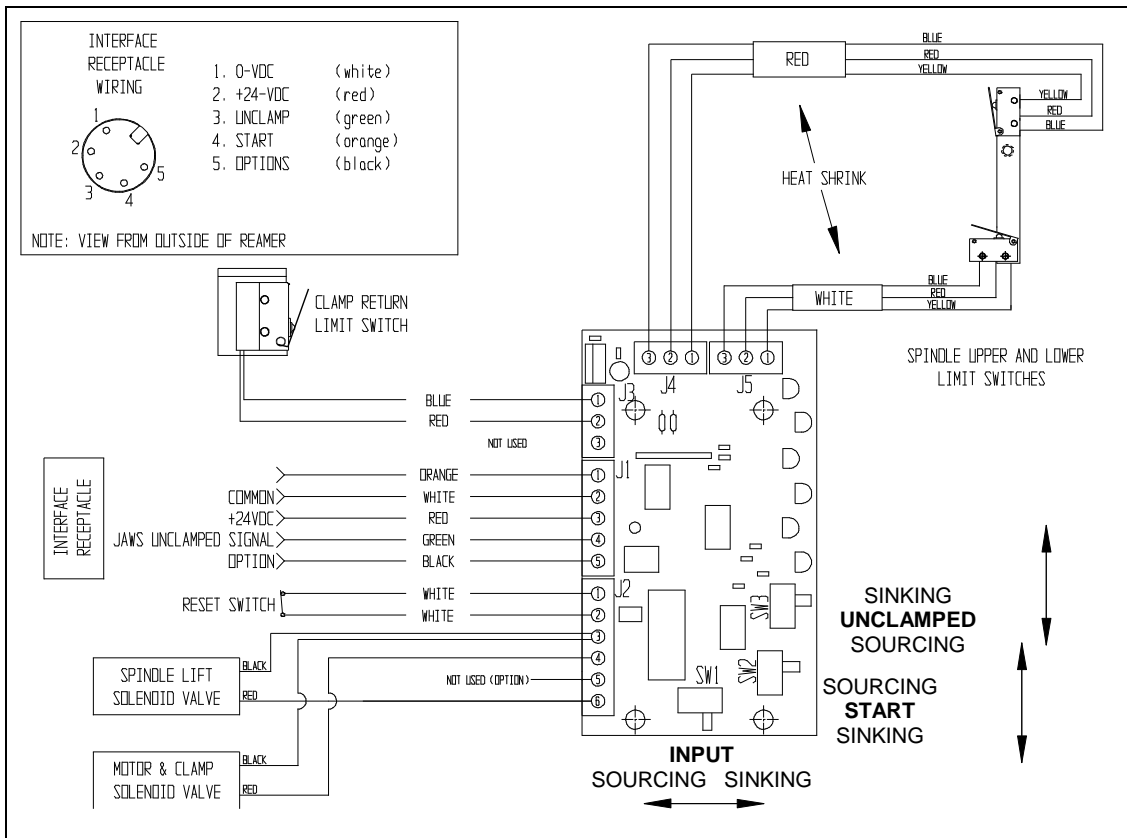

4.3 CUTTER AND V-BLOCK CHART

NOZZLE PART #	NOZZLE OUTSIDE DIAMETER	REAMER MODEL	V-BLOCK PART #	CUTTER PART #
401-4-38	0.938"	TT-0938-06	TR-2150	RC-06
401-40-38	0.978"	TT-0978-06	TR-2151	RC-06
401-45-38	0.938"	TT-0938-06	TR-2150	RC-06
401-45-38	0.938"	TT-0938-06	TR-2150	RC-06
401-46-38	0.938"	TT-0938-06	TR-2150	RC-06
451-4-38	0.938"	TT-0938-06	TR-2150	RC-06
401-4-50	0.938"	TT-0938-04	TR-2150	RCT-04
401-6-50	1.062"	TT-1060-04	TR-2150	RCT-04
401-42-50	0.938"	TT-0938-04	TR-2150	RCT-04
401-44-50	0.938"	TT-0938-04	TR-2150	RCT-04
401-45-50	0.938"	TT-0938-04	TR-2150	RCT-04
401-46-50	0.938"	TT-0938-04	TR-2150	RCT-04
401-47-50	0.938"	TT-0938-04	TR-2150	RCT-04
401-48-50	0.938"	TT-0938-04	TR-2150	RCT-04
451-6-50	0.938"	TT-0938-04	TR-2150	RCT-04
401-4-62	0.938"	TT-0938-01	TR-2150	RCT-01
401-5-62	1.062"	TT-1060-01	TR-2150	RCT-01

401-6-62	1.062"	TT-1060-01	TR-2150	RCT-01
401-7-62	1.106"	TT-1106-01	TR-2150	RCT-01
401-8-62	0.938"	TT-0938-01	TR-2150	RCT-01
401-9-62	0.938"	TT-0938-01	TR-2150	RCT-01
401-45-62	0.938"	TT-0938-01	TR-2150	RCT-01
401-46-62	0.938"	TT-0938-01	TR-2150	RCT-01
401-48-62	1.062"	TT-1060-01	TR-2150	RCT-01
401-72-62	1.062"	TT-1060-01	TR-2150	RCT-01
401-81-62	1.062"	TT-1060-01	TR-2150	RCT-01
401-87-62	1.062"	TT-1060-01	TR-2150	RCT-01
451-1-62	1.062"	TT-1060-01	TR-2150	RCT-01
451-5-62	0.938"	TT-0938-01	TR-2150	RCT-01
451-6-62	0.938"	TT-0938-01	TR-2150	RCT-01
451-8-62	0.938"	TT-0938-01	TR-2150	RCT-01
451-61-62	1.062"	TT-1060-01	TR-2150	RCT-01
451-81-62	1.062"	TT-1060-01	TR-2150	RCT-01
451-87-62	1.062"	TT-1060-01	TR-2150	RCT-01
650-5-62	1.062"	TT-1060-01	TR-2150	RCT-01
650-6-62	1.062"	TT-1060-01	TR-2150	RCT-01
651-5-62	1.062"	TT-1060-01	TR-2150	RCT-01
651-6-62	1.062"	TT-1060-01	TR-2150	RCT-01
401-4-75	.0938"	TT-0938-12	TR-2150	RC-12
401-5-75	1.062"	TT-1060-12	TR-2150	RC-12
401-6-75	1.062"	TT-1060-12	TR-2150	RC-12
401-7-75	1.106"	TT-1106-12	TR-2150	RC-12
451-1-75	1.062"	TT-1060-12	TR-2150	RC-12
451-5-75	0.938"	TT-0938-12	TR-2150	RC-12
451-6-75	0.938"	TT-0938-12	TR-2150	RC-12
650-5-75	1.062"	TT-1060-12	TR-2150	RC-12
650-6-75	1.062"	TT-1060-12	TR-2150	RC-12
651-5-75	1.062"	TT-1060-12	TR-2150	RC-12
651-6-75	1.062"	TT-1060-12	TR-2150	RC-12

5.0 EXPLODED VIEW & PARTS LIST

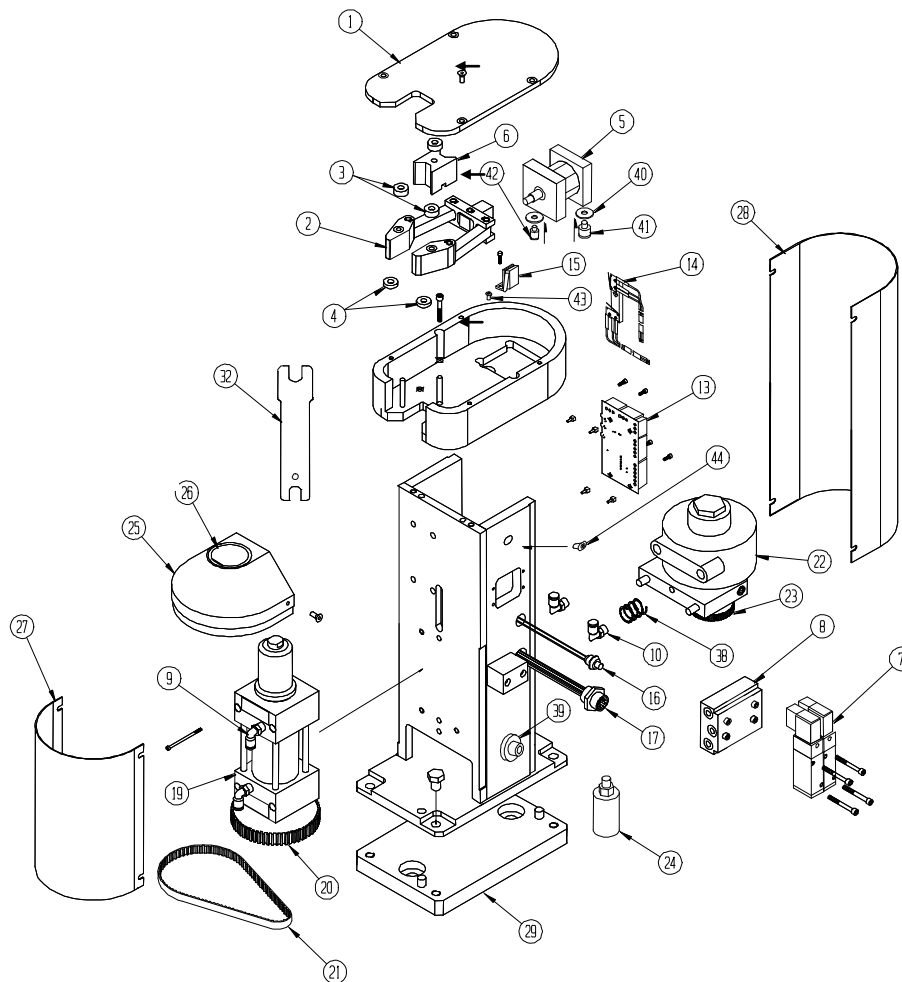

ITEM	PART#	DESCRIPTION	ITEM	PART #	DESCRIPTION
1	TR-2110	CLAMP COVER	22	TR-2500	AIR MOTOR ASSEMBLY w/pulley
2	TR-2120	JAW ASSEMBLY	23	TR-2520	MOTOR PULLEY
3	TR-2127	UPPER JAW SPACER (2req'd)	24	TR-2530	MUFFLER
4	TR-2128	LOWER JAW SPACER (3req'd)	25	TR-2660	SPINDLE CAP
5	TR-2130	CLAMP CYLINDER	26	TR-2661	SPINDLE CAP SEAL
5a	TR-2130R	CLAMP CYLINDER SEAL KIT (not shown)	27	TT-2670	SPINDLE SHROUD
6	XXX	V-BLOCK (refer to chart on page 10-11)	28	TT-2680	MOTOR SHROUD
7	TR-2210	SOLENOID VALVE	29	TR-2690	ADAPTOR PLATE (OPTIONAL)
7A	TR-2210-2	VALVE SCREWS (M3X30mm SHS)	N/S	TR-2234	FLOW CONTROL
7B	TR-2215	GASKET (not shown)			SERIAL #TT-5338 & EARLIER -2 EACH REQ.
8	TR-2220	VALVE BASE (TR-2221 Vent not included)			SERIAL #TT-5339 & UP -1 REQUIRED
9	TR-2235	AIR FITTINGS-MALE ELBOW (Spindle unit)			
10	TR-2236	AIR FITTINGS-MALE ELBOW (Motor)			
11	TR-2250	AIR LINE 1/4", 4FT. LENGTH (not shown)	N/S	TT-2412	FIXED FLOW CONTROL
12	TR-2260	AIR LINE 5/16", 4FT. LENGTH (not shown)			SERIAL #TT-5339 & UP
13	TR-2310	P.C BOARD	31	RR-707-30	TCP LOCATOR PIN (optional - not shown)
13A	TR2310-S	STANDOFF SCREW KIT	32	TR-2910	CUTTER WRENCH
14	TT-2322	SPINDLE LIMIT SWITCH ASSEMBLY	33	RC-00	ALIGNMENT TOOL (not shown)
15	TR-2321	CLAMP SWITCH	34	RT-1000	TEST BOX (not shown)
16	TT-2330	RESET SWITCH (w/TT-2330-2 boot)	35	TT-2400RN	LIFT CYLINDER SEAL REPAIR KIT (not shown)
		REPLACES TR-2330	36	TT-2400R	LIFT CYLINDER SEAL REPAIR KIT (not shown)
	TR-2330-2	SWITCH BOOT			<For older generation blue cylinder>
17	TR-2340	INTERFACE RECEPTACLE	38	TR-2512	MOTOR TENSION SPRING
18	TR-2350	CONTROL CABLE - 20' supplied standard	39	TR-2632	WASHER
	TR-2350-30	CONTROL CABLE - 30' optional (not shown)	40	TR-2239	RING WASHER (2)
	TR-2350-50	CONTROL CABLE - 50' optional (not shown)	41	TR-2231	AIR FITTING 5/16" SMC
19	TT-2400	SPINDLE UNIT ASSY' w/pulley	42	TR-2232	AIR FITTING 1/4" SMC
			43	TR-2452	TOP MOUNT GROMMET
20	TR-2430	SPINDLE PULLEY	44	TR-2451	SIDE MOUNT GROMMET
21	TR-2440	DRIVE BELT	N/S	TR-2453	REAMER GROMMET & SEAL KIT
					(INCLUDES ITEMS - 15, 40, 43 & 44)

6.0 TROUBLESHOOTING

PROBLEM	POSSIBLE CAUSE	SOLUTION
LED signals not activating	<ul style="list-style-type: none"> • Power is off • Fuse is blown • REAMER station is not switched on • Input voltage is incorrect 	<ul style="list-style-type: none"> • Turn power on • Install new fuse • Switch unit on • Check input voltage and make adjustments as required.
Motor stops during operation	<ul style="list-style-type: none"> • Air supply is incorrect • Excessive spatter build up • Lubricator not installed or adjusted properly 	<ul style="list-style-type: none"> • Set at 80-100 PSI at 16 CFM • Apply or increase quantity of anti-spatter • Increase frequency of torch cleaning or modify welding parameters • Ensure lubricator is installed and adjusted (ref to sec.1.2)
Pneumatic functions not operative	<ul style="list-style-type: none"> • Air line damaged or obstructed • Air supply incorrect • Faulty reset switch 	<ul style="list-style-type: none"> • Replace air line • Check air supply. Set at 80-100 PSI at 16 CFM • Repair or replace reset switch
Broken cutter	<ul style="list-style-type: none"> • Improper cutter being used • Flow control valve set too low • Flow control valve shut 	<ul style="list-style-type: none"> • Repair or replace damage components • Adjust feed rate • Adjust flow control valve
Reamer stays in up position	<ul style="list-style-type: none"> • Cutter is jammed in torch • Faulty spindle unit • Faulty limit switch • Cycle start signal held on too long 	<ul style="list-style-type: none"> • Press or replace damage components • Repair or replace unit • Repair or replace limit switch • Revise program (.5 sec. pulse)
Cycle complete signal does not activate	<ul style="list-style-type: none"> • Faulty clamp unit • Faulty circuit board 	<ul style="list-style-type: none"> • Check or replace switch
Spindle (cutter) keeps cycling up & down while spinning	<ul style="list-style-type: none"> • Interface receptacle or control cable plug may be dirty. 	<ul style="list-style-type: none"> • Unplug control cable from reamer and clean both connections thoroughly.

7.0 SPRAYER

7.1 OPTION (S): ANTI-SPATTER SPRAYER

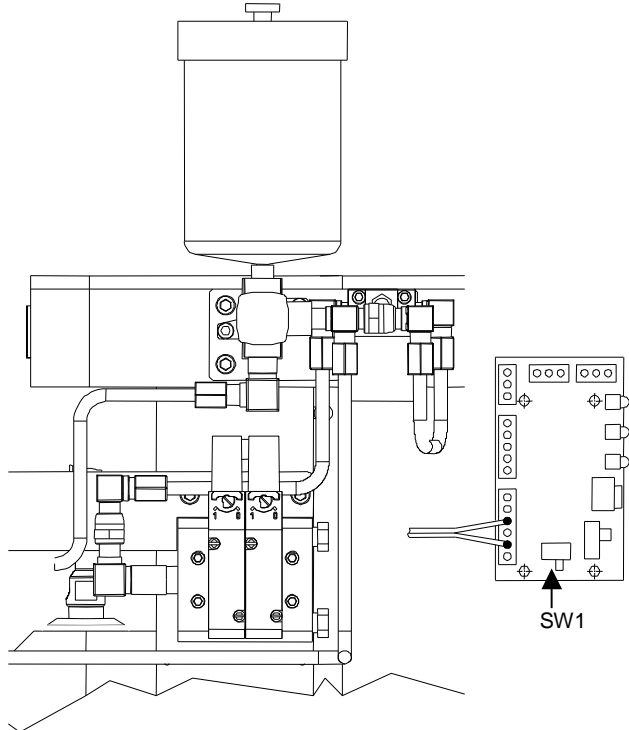

- The TOUGH GUN® Sprayer is factory set for “sourcing”. The wires are connected to the P.C. board as shown.
- If you require the P.C. board switches to be set to the “sinking” position, the switch (SW1) must be moved to sinking position (identified on board)
- To operate the sprayer, a timed 24 VDC signal must be applied to the black lead (optional) of the interface receptacle. Recommended spray time .5sec. (refer to sprayer tech guide).

7.2 PROGRAMMING EVENTS SEQUENCE

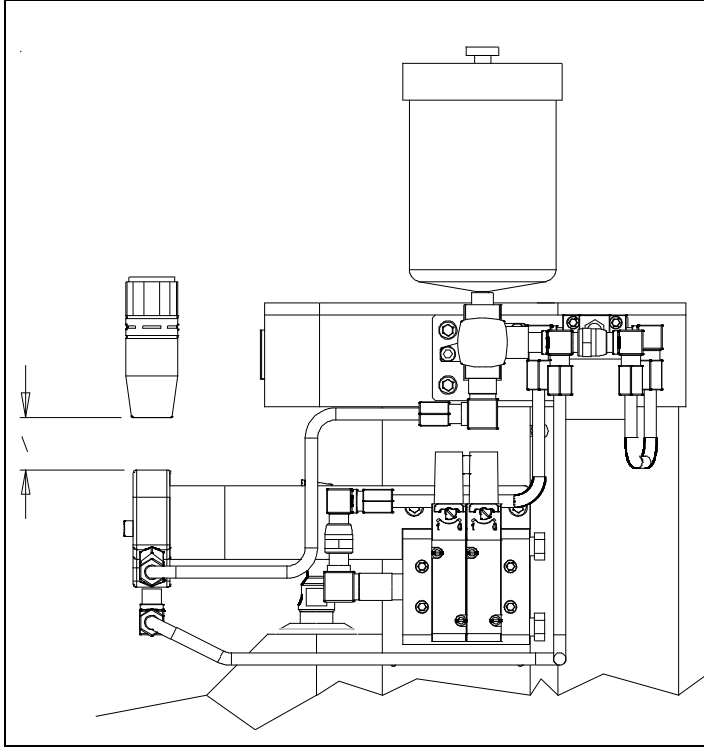

- Program robot so that nozzle is centrally located.
X = 1.25" when using 5/8" Bore Nozzles
X = 1" when using 1/2" Bore Nozzles
X = 1.5" when using 3/4" Bore Nozzles
- Energize timed output signal to initiate spray cycle. Set timer at .5 seconds for initial set-up. Adjust timer to increase or decrease quantity of anti-spatter compound as required by process.
- **NOTE:** If using Tregaskiss TOUGH GARD Anti-Spatter compound, spray time can be as low as .2 seconds. Anti-spatter compound should be enough to coat inside of nozzle with no drippage. Excessive application of TOUGH GARD can decrease performance and increase consumption.
- **IMPORTANT:** If using the optional air-blast **DO NOT** activate air blast when over the spray head. Dirt/spatter may be blown into the spray head orifice, which may hamper spray operation.

7.3 SPRAYER MAINTENANCE

DAILY

Ensure fluid level in reservoir is maintained. Inspect spray operation to ensure adequate anti-spatter compound is being applied.

WEEKLY

Inspect unit for air leaks or damage supply and interface lines which may cause unit to malfunction.

QUARTERLY

Inspect unit for build up of residue from anti spatter compound which could eventually restrict fluid flow or cause unit to malfunction. Residue should be visible in reservoir or nozzle assembly. If excessive, clean or flush with recommended solvent for anti-spatter compound.

YEARLY

Inspect unit for damage or excessive wear of components. Replace if required.

7.4 SPRAYER TROUBLESHOOTING

PROBLEM	POSSIBLE CAUSE	SOLUTION
No Air Flow No Anti-spatter	<ul style="list-style-type: none"> • Output to unit not functioning • Fuse blown • Loss of air supply • Faulty solenoid valve 	<ul style="list-style-type: none"> • Check output signal and cable • Install new fuse • Check air supply • Check air line and nozzle for blockage • Check solenoid valve and replace if required
Air Flow But No Anti-Spatter	<ul style="list-style-type: none"> • Vent closed on reservoir • Nozzle position incorrect on spray head • Spool in valve block stuck • Fluid line blocked • Inadequate air pressure 	<ul style="list-style-type: none"> • Open vent • Adjust nozzle position on spray head • Repair or replace valve block • Clean or repair fluid line • Ensure 80 psi
Spray head plugged		<ul style="list-style-type: none"> • Clean spray head

7.5 SPRAYER PARTS LIST

TENCHNICAL DATA

Electrical: 24 volts DC
 2.5 watts
 Pneumatic: 80-100 PSI
 at 16 CFM
 (Uses Reamer Air Supply)

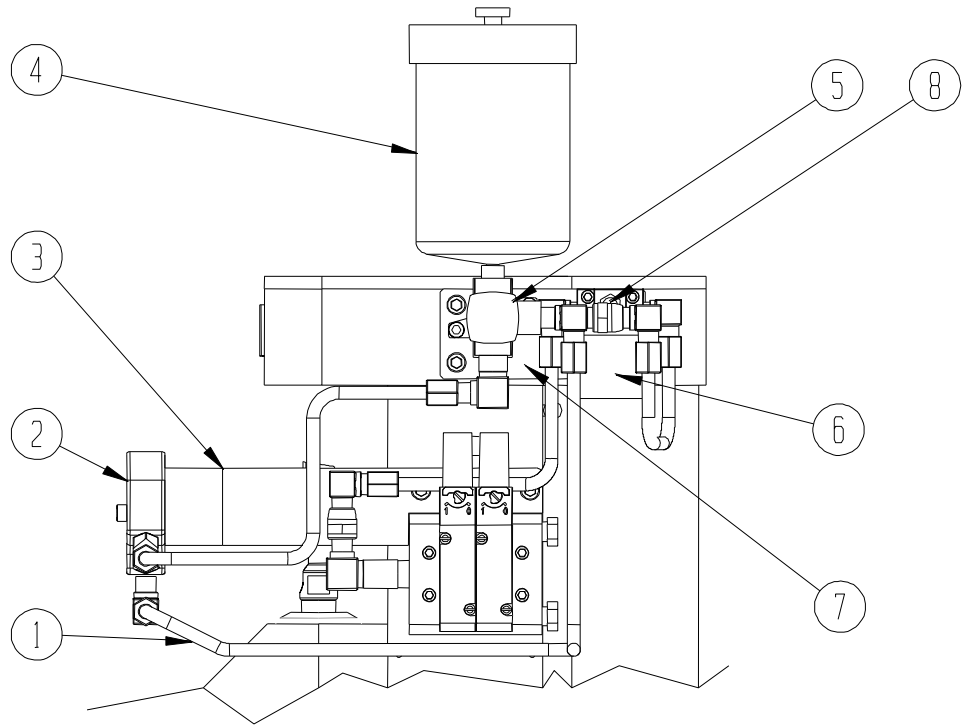

ITEM	PART #	DESCRIPTION
1	TS-500-50	STEEL LINE KIT
2	TS-500-15	SPRAY HEAD
3	TS-500-1	SPRAY HEAD BRACKET
4	RR-1320	RESERVOIR
5	TS-500-20	CHECK VALVE
6	TS-500-28	SOLENOID VALVE
7	TS-500-29	MOUNTING PLATE
8	RS-500-20	BREATHER VENT

NOTE: Older sprayer units utilized plastic air lines and can be updated using the TS-500-50 Steel line kit and TS-500-15 spray head.

8.0 OPTIONS

8.1 Options '10' or '12' – REAMER STAND with optional FRL (Filter Regulator Lubricator)

<p>Option '10'</p>	<p>Option '12'</p>		
PART #	DESCRIPTION	PART #	DESCRIPTION
RST-1000-A	ADJUSTABLE REAMER STAND (28" TO 43")	RST-1200-A	ADJUSTABLE REAMER STAND WITH FRL (28" TO 43")

8.2 Option 'B' – Multi-Feed Ready Reamer

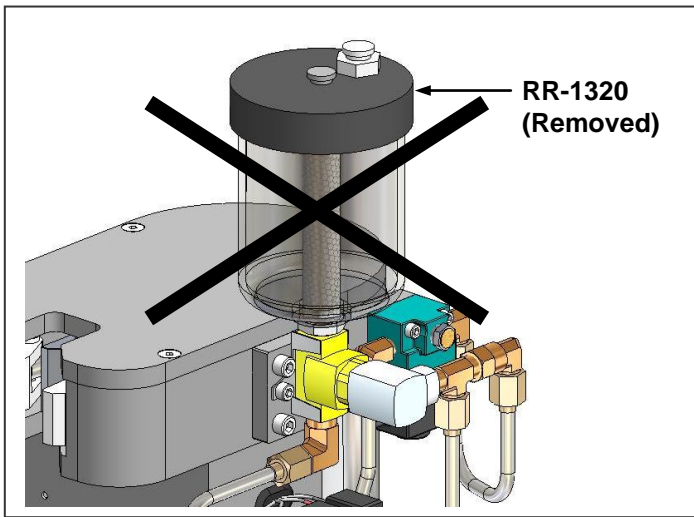

Choosing Reamer option 'B' (Multi-feed Ready Reamer), removes the Sprayer Reservoir (RR-1320) from the bill of material, since it is not needed with the Multi-feed System.

A diagram below shows one of many Multi-feed configurations. Refer to our website or your local Tregaskiss representative for more information.

NOTE:
Multi-feed Systems are sold separately.

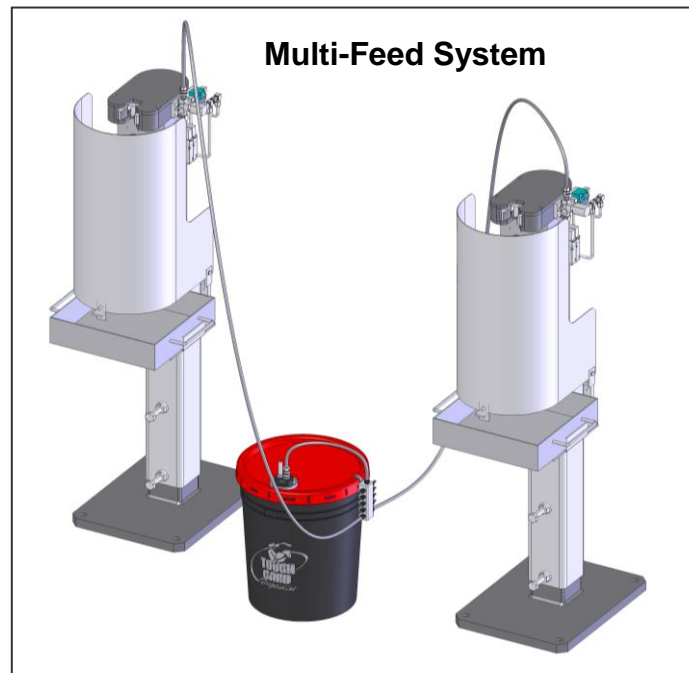
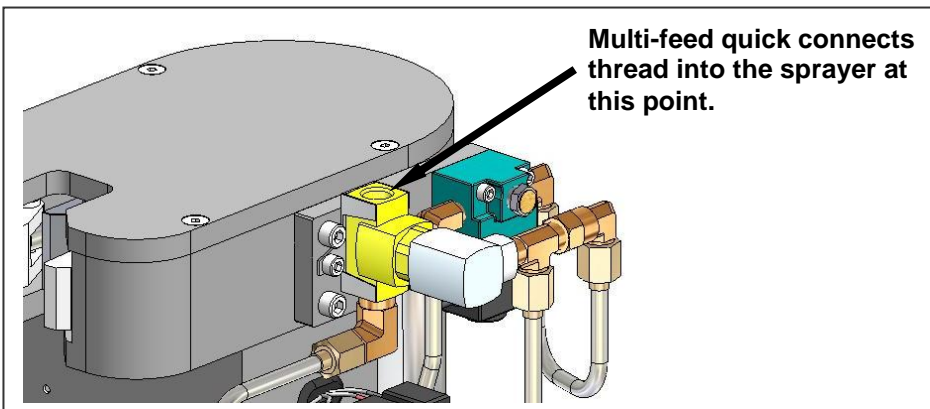

8.0 OPTIONS

8.3 Option 'C' – Flow Control

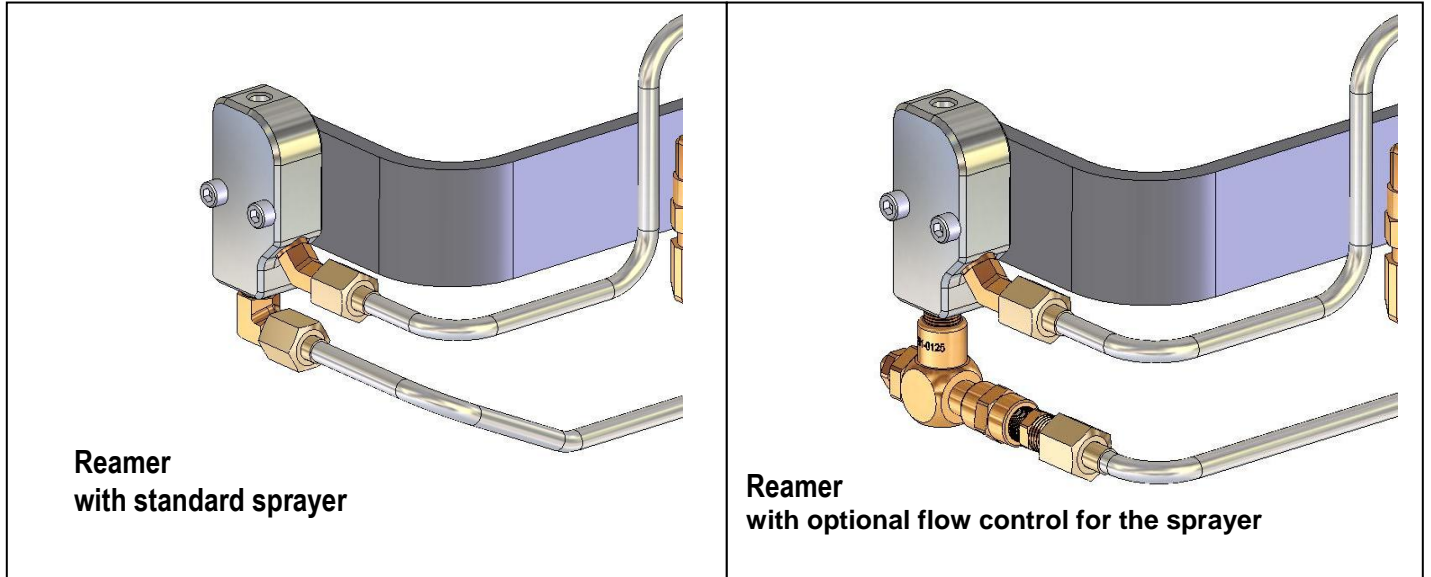

Note : Choosing Reamer option 'C' – Flow Control adds an adjustable check valve, giving users the ability to control the amount of Tough Gard applied in each spray.
Also available the retro-fitable flow control kit. (Part# TS-500-52).

8.4 Option 'W' – Wire Cutter

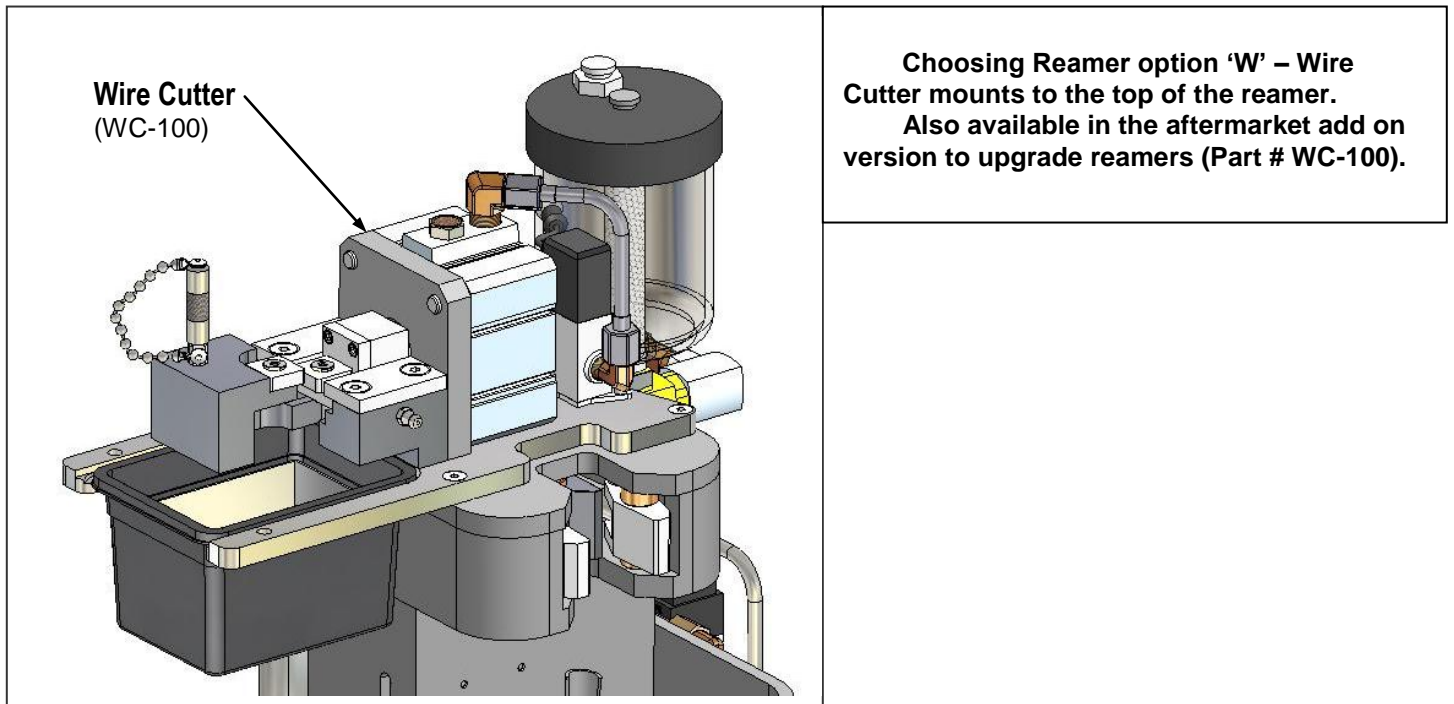

9.0 - TOUGH GUN ORDERING INFORMATION

Building a TOUGH GUN REAMER part number

TT - XXXX - XX - X - XX - XX

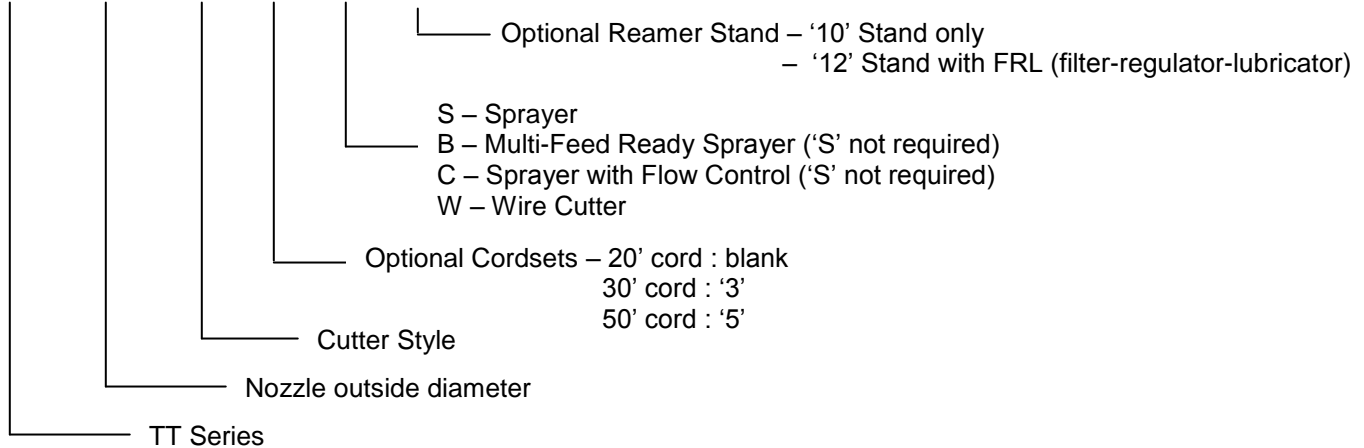

Order Number Examples:

TT - 0938 - 01 - 3 - BCW - 10

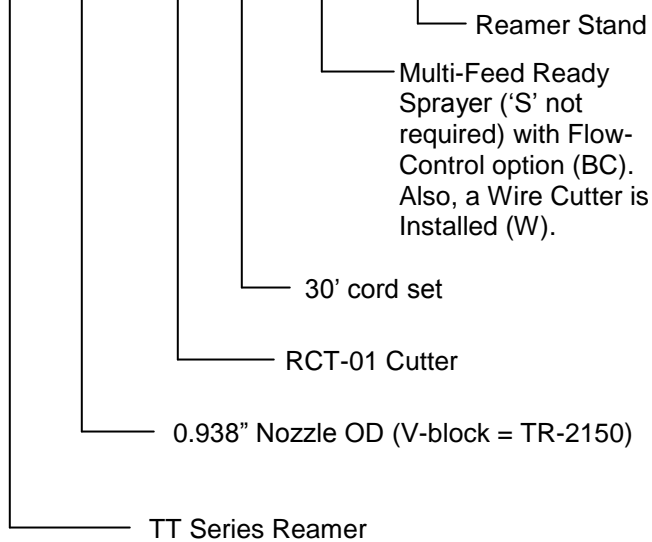

TT - 1060 - 01 - 5 - SW - 12

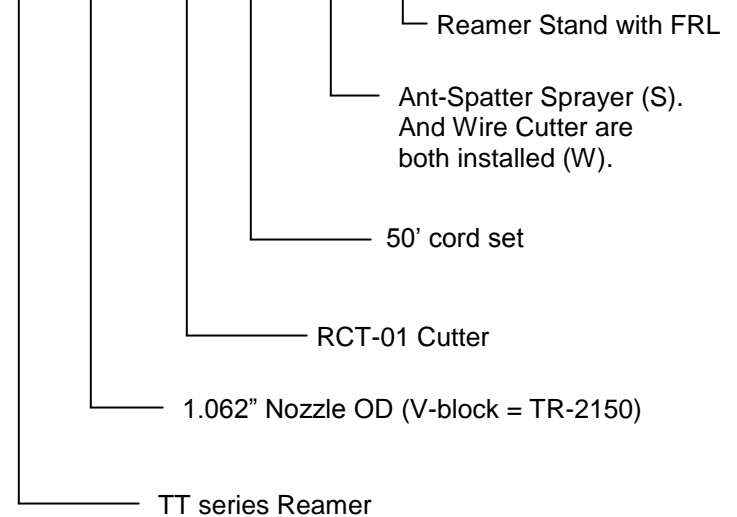

THE FREEDOM TO INNOVATE

Canada & U.S.A. Phone: 1-877-737-3111
Fax: 1-877-737-2111

International Phone: +1-519-737-3000
Fax: +1-519-737-2111

www.tregaskiss.com

Distributed by:

2/26/07 REV C

M061