

# How to Install or Replace a Neck on TOUGH GUN™ G1 Series Robotic Air-Cooled MIG Guns

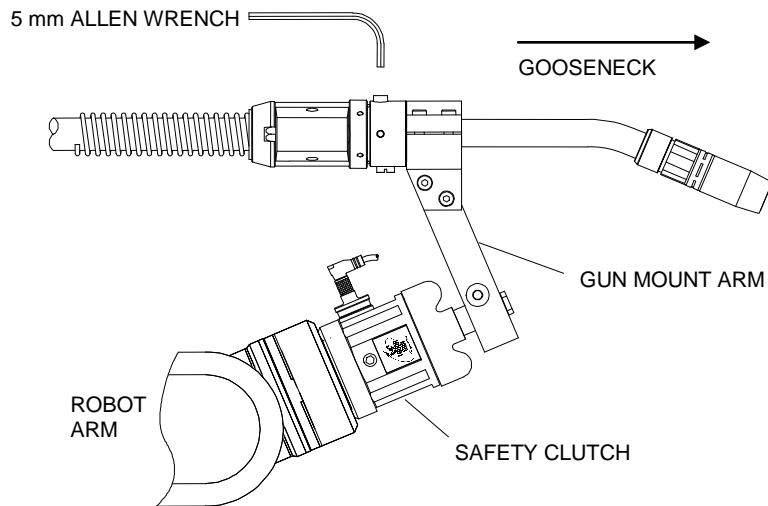

## STEP #1



- There is a protective ring that must be rotated to expose the gooseneck set screw.
- Using a 5 mm Allen wrench, loosen screw 1/4 turn to remove neck.
- Pull gooseneck directly out of connector cone assembly.

## STEP #2

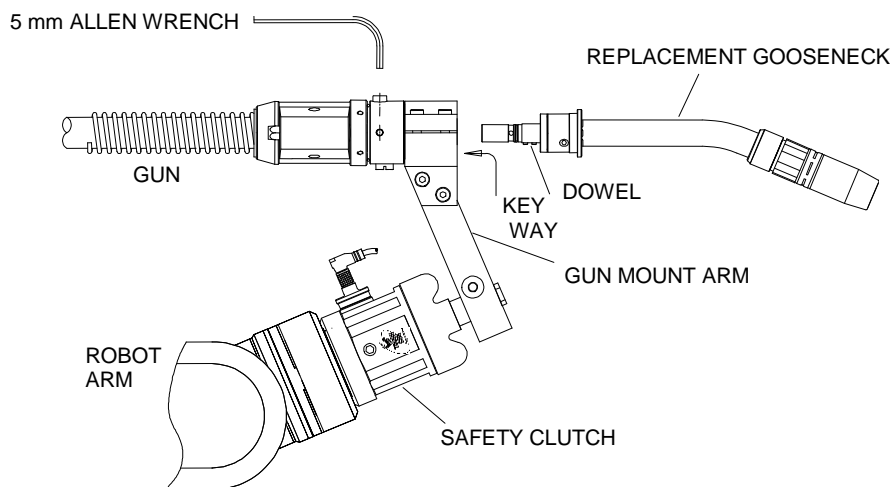

- Insert replacement gooseneck into gun housing, ensuring key on gooseneck is lined up with key way.
- **NOTE:** If face of body on gooseneck cannot be pushed flush to gun housing, then check seating of liner in retainer head.
- Tighten set screw (max. 60 in.-lbs. (7 Nm)).